



(12) **EUROPEAN PATENT APPLICATION**

(21) Application number: **91102520.3**

(51) Int. Cl.⁵: **A63H 7/00, A63H 3/20, A63J 19/00**

(22) Date of filing: **21.02.91**

(30) Priority: **28.02.90 FR 9002515**

(71) Applicant: **Colombo, Alessandro**
52, rue du Page
B-1050 Brussels(BE)

(43) Date of publication of application:
04.09.91 Bulletin 91/36

(72) Inventor: **Colombo, Alessandro**
52, rue du Page
B-1050 Brussels(BE)

(84) Designated Contracting States:
AT BE CH DE DK ES FR GB GR IT LI LU NL SE

(74) Representative: **Kovacs, Paul et al**
NOVAPAT - CABINET CHEREAU 9, rue du
Valais
CH-1202 Genève(CH)

(54) **Puppet toy.**

(57) A puppet toy of the type comprising a puppet (1) which is attached to the upper end of an operating bar (5) and which comprises a lower housing (2) having an upper opening which is closed by the lower edge of the dress (4) of the puppet and across which extends said operating bar (5) is provided with a housing having the shape of e.g. a straight cone or other, which includes a lower opening (6) receiving said operating bar (5). Said bar (5) may comprise a rocking portion (7) which permits a movement of the puppet (1) in a direction perpendicular to the axial direction of the operating bar. The puppet toy according to the present invention may also comprise various sound means (9), light means (11) and/or mechanical drive means (13, 14) which are driven electrically.

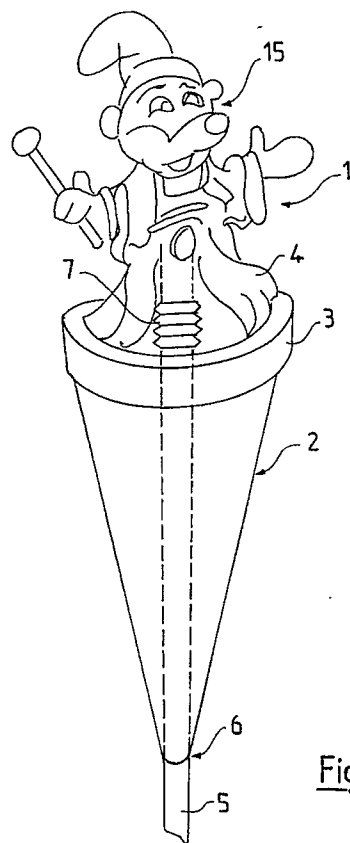

Fig. 3a

EP 0 444 528 A1

The present invention relates to a puppet toy of the type having a puppet which is fixed on the upper end of an operating bar and a lower housing having an upper opening which is closed by a lower edge of the clothes of the puppet and across which the operating bar extends, as well as a lower opening which receives the operating bar.

In figure 1 a puppet toy is illustrated such as described in US patent 4'804'348, which puppet toy is arranged in a box constituting a puppet theatre, such that the puppet is fixed on the upper end of an operating bar, which is driven into an axial reciprocating movement by a driving means which comprises a rotating excentrical cam. The lower portion of the puppet is connected to the large opening of a horn of which the small opening is bent backwardly towards the rear of the box and the horn further comprises a lower opening through which the operating bar can exit from the horn in order to reach the driving means mentioned hereinabove.

It is the object of the present invention to create an independent puppet toy which comprises a puppet fixed on the upper end of an operating bar, and which comprises a lower housing which permits the manipulation of the puppet toy in a sense perpendicular to the axis of the operating bar. Thus, the invention creates a puppet toy, wherein the puppet is capable of carrying out a lateral movement which may not be obtained with a puppet toy such as described in US patent 4'804'348.

Other objects of the present invention are related to complementary functions of the puppet toy such as the provision of sound or light means in order to make the puppet toy more attractive or to the decoration of the lower housing.

It is also an object of the present invention to provide a puppet toy of the type such as described hereinabove which is capable of an automatic movement in a direction parallel to the axis of the operating bar.

These objects are achieved with a puppet toy of the type mentioned hereinabove which is further characterized in that the lower opening is arranged such as to permit a pivotal movement of the operating bar around a point which is situated at the lower opening.

This operating bar may extend across the lower housing such as to traverse the upper and lower openings, the upper opening being larger than the lower opening.

The operating bar may comprise a rocking section, which allows the puppet a lateral movement with respect to the axial direction of the bar. Advantageously this rocking section may be arranged on the bar at a point which is situated within the puppet above the upper opening of the

conical housing.

According to a particular embodiment of the present invention the puppet toy may comprise a sound means which may be provided in the form of a sound mechanism or an electrical device, and which can be located within the conical housing, in particular fixed to the inner surface of the latter. In order to facilitate dissipation of the sound towards the exterior of the housing, an opening may be provided in the conical housing where the sound means is fixed thereon.

According to a different embodiment of the present invention the puppet toy may comprise a light means such as luminescent diodes which may be arranged in the eyes of the puppet and/or at any other desired location of the puppet or of the conical housing. These diodes may be in colour, particular in different colours depending on their location.

In order to make the puppet toy more attractive one may affix stickers at the outer surface of the conical housing at any desired location.

According to another embodiment of the present invention the puppet toy comprises a drive means in order to drive the operating bar into an axial reciprocating movement, whereby these drive means may be constituted by a pinion which is driven into rotation and which comprises teeth disposed on a portion of the circumference of the pinion only, whereby the operating bar comprises a section which is provided with circumferential grooves such that the teeth of the pinion can engage into the grooves and thus provoke an axial displacement of the bar in response to the rotation of the pinion.

The operating bar may be slightly solicited into a direction opposite to the movement which is provoked by the pinion, and it may therefore return into its initial position as soon as the portion of the pinion which does not comprise any teeth opposes the grooves of the bar.

According to another aspect of the present invention the operating bar comprises at its upper end a slightly enlarged portion in order to elastically snap into the interior of the head of the puppet which comprises a corresponding recess, the entry thereof being slightly smaller than the enlarged portion of the bar.

The head of the puppet may comprise a lower cylindrical collar which surrounds the operating bar and which includes an outer circumferential groove, which serves for the attachment of the collar of the dress of the puppet by means of an elastical or non-elastical string.

The puppet toy may comprise a trigger for an electrical current provided by a battery, which trigger is arranged outside of the lower housing, and by which the sound means, the light means and/or

the driving mechanism for the operating bar can be put into action.

The puppet toy may comprise a lower housing in the form of a straight cone, of a barrel, of a cylinder or of any other shape constituting rotative symmetry, however, the housing of the puppet toy may also be in the shape of a heart or of a flower which does not comprise a rotative symmetry with respect to the axis of the housing.

In the two last mentioned cases, which is the shape of a heart or a flower, the housing is constituted by an enclosure which is traversed by the operating bar in a sense parallel to the essentially plane main surfaces such that the lower and upper openings of the housing are arranged in wall portions which lie in a surface created by the movement of the generatrix following the curves of a heart or of a flower.

In the two last mentioned cases, the lower edges of the dresses of the puppet are fixed within the upper opening of the housing by means of a ring which may be engaged with the interior of this opening and which, in this position, squeezes the lower edge of the dresses between the wall portion surrounding said upper opening and itself.

In another embodiment of the present invention the lower housing comprises a lateral opening which is provided with a hollow cylinder which projects towards the exterior, the hollow portion of which communicates with said lateral opening, and which houses a whistle means, whereas the hollow cylinder serves for the attachment of a flexible tube which comprises at its free end a mouth piece permitting to trigger the whistle means in response to blowing into the mouth piece.

According to a still further embodiment of the present invention the lower housing comprises a switch by which any electrically operated means of the puppet toy may be connected to or separated from a battery which is positioned in the lower housing.

The puppet toy according to the present invention may also comprise an acoustic trigger in order to switch any of the electrical functions of the puppet toy, such as the sound means, the light means and/or the driving mechanism.

The present invention will now be described in detail with reference to the drawings whereof

Figure 1

is a puppet toy according to the prior art,

Figure 2

is an embodiment of the present invention,

Figures 3a,b,c,

are particular embodiments of the present invention representing a particular function,

Figure 4

illustrates a particular aspect of the present invention,

Figure 5

illustrates another particular aspect of the present invention,

Figure 6

illustrates still another aspect of the present invention,

Figures 7a,b,c

show an example for a driving mechanism,

Figure 8

shows two details of an attachment for the assembly of the puppet and,

Figures 9 to 14

illustrate other embodiments of the present invention.

Figure 2 illustrates a puppet toy comprising a puppet (1) which is located above a lower conical housing (2), the dress (4) of the puppet being attached to the upper opening of the conical housing (2) by means of a ring (3), the inner dimensions of which cooperate with the outer dimensions of the upper opening of the conical housing (2) such as to squeeze the lower edge of the dress (4) between the conical housing (2) and the ring (3).

The lower conical housing (2) comprises a lower opening (6) through which extends an operating bar (5) which traverses in essentially axial direction the entire conical housing (2) in order to exit therefrom through the upper opening whereby it further extends until the head (15) of the puppet, which it supports in a mobile fashion.

Manual actuation of the bar (5) in the axial sense of the bar or in a sense slightly pivoting around a point situated at the level of the lower opening (6) of the lower conical housing (2) creates a movement of the puppet in a vertical or horizontal sense respectively.

It is evident, that the shape of the lower housing permits the pivoting movement of the operating bar, because the operating bar (5) may freely pivot within an angle limited only by the shape of the conical housing, whereby the arrangement of the operating bar in the puppet toy according to the prior art does not permit such movement.

Figure 3a corresponds to figure 2 with the only exception that the operating bar (5) comprises a rocking portion (7) which permits a particular movement of the upper portion of the operating bar (5).

This particular movement is illustrated in figures 3b and 3c and is created as described below :

Following a pivoting movement of the operating bar (5) within the lower housing (2) such as indicated in figure 3b, portion (8a) of the dress (4) of the puppet and situated on the side of the puppet which is opposed to the direction into which the upper portion of the operating bar (5) is moved, is straightened when the operating bar (5) arrives at a certain angle. After continuation of the pivoting movement of bar (5) into the same direction, the

upper portion of the bar cannot follow anymore this pivoting movement, because it is withheld by portion (8a) of the dress. Under the force which is applied to continue the pivoting movement of the operating bar (5), rocking portion (7) yields and permits bending of the upper portion of the bar with respect to the rest of the bar.

Such bending results in the fact that puppet (1) seems to rock into a direction opposed to the direction of the pivoting movement of the operating bar (5), which rocking movement is reversed as soon as the operating bar (5) is returned into its axially symmetrical position.

Figure 3c illustrates a pivoting movement of the operating bar (5) in the counter sense followed by a rocking movement of the puppet (1) in a sense corresponding to the withholding of portion (8b) of the dress (4) of the puppet (1).

Figure 4 illustrates a puppet according to the present invention comprising a sound means (9) which is attached to the inner surface of the lower conical housing (2) which is provided with an opening in the proximity of the sound means in order to permit dissipation of the sound to the outside of the housing.

The sound means may consist of any appropriate mechanism which produces sound, such as typically known sound mechanisms.

The sound means may also be formed by an electrical means such as traditionally used for various sorts of applications, such as for tee-shirts, for postcards, etc...

Figure 5 shows an embodiment of the present invention in which a light means is used which consists of luminescent diodes which are arranged in the eyes of the puppet and for which electrical current may be provided from a battery which is located within the lower conical housing (2), the electrical current may be controlled by means of a trigger button (10) which is arranged outside of the housing (2).

Trigger button (10) or any other trigger button of the same type may be provided in order to also control the sound means (9) of figure 4.

In order to make the puppet toy of the present invention still more attractive, one can affix stickers of different shape and colours onto the outer surface of the lower conical housing (2) such as illustrated in figure 6.

Figures 7a, b and c represent a schematical illustration of a driving mechanism for the operating bar (5) in view of a reciprocating axial movement thereof. This mechanism comprises a pinion (13) whereof only a portion of its periphery comprises teeth (16), portion (17) being flat and having a diameter which is smaller than the distance between the center of the pinion and the tops of the teeth (16) of pinion (13).

In figure 7a the bar (5) is illustrated in its lower position, and pinion (13) is in an orientation where teeth (16) begin to engage in grooves (14) of the bar (5). Following rotation of pinion (13) in the sense indicated by the arrow, bar (5) is driven into an axial upward movement, until it arrives in its upper position such as indicated in figure 7b in which the engagement of the last tooth (16') within the last groove (14') of bar (5) is shown.

After continuation of the rotation of pinion (13) in the same direction, the peripheral portion of pinion (13) which comprises teeth (16) disengages from grooves (14) of the bar (5) and the latter returns into its lower position, into which it is solicited by any type of not-shown spring means or simply by its weight.

Figure 7c shows the disengagement of the teeth of pinion (13) from grooves (14) of the bar (5) followed by the downwards movement towards the lower position of the operating bar (5).

Such mechanism may be utilised in a way where pinion (13) is continuously driven by an electrical motor which is supplied from the same battery which also supplies energy to the sound and the light means.

Obviously one may also provide a mechanism having a complete pinion which rotates in alternating directions.

Figure 8 illustrates a detail for the assembly of the puppet, in particular for its head, which comprises a recess (20) and a collar (21) such that recess (20) presents a diameter which is larger than its introduction opening (22) which corresponds to the inner diameter of the collar (21), which is arranged immediately below the head of the puppet such that the inner surface (23) of the collar is exactly aligned with the introduction opening (22) of recess (20) of the head.

The operating bar (5) comprises an upper portion (24) which is slightly enlarged such that it may be introduced into recess (20) after traversing collar (21), whereby it snaps elastically into said recess and creates thus a reliable attachment between the head of the puppet and the operating bar (5).

Figure 8 shows also another aspect of the present invention relating to the attachment of the upper portion of the dress onto the neck of the puppet.

This attachment means comprise a circumferential groove (25) on the outer surface of the collar (21), which groove serves to receive an elastic or a non-elastic string (26) by which the upper portion of the dress may be squeezed into the interior of groove (25).

Figure 9 shows another embodiment of a lower housing for the puppet toy according to the present invention, whereby the lower housing comprises

the form of a barrel (2') which comprises a lower opening (6) having a size approximately equal to the section of the operating bar (5), which permits also a pivoting movement of said bar around a point situated at the level of opening (6). Such pivoting movement is limited only by the size of the upper opening as defined by the interior of ring (3).

Figure 10 shows an optional function with which the puppet according to the present invention may be provided, and which consists of a whistle (28) which is arranged within the hollow portion of a cylinder (29') which is situated outside of an opening (29) in the lower housing of the puppet toy.

Hollow cylinder (29') serves also as a support for the end of a flexible tube (27) which comprises at its other end a mouth piece (30) by which one may blow into the tube (27) in order to actuate the whistle (28).

Figure 11 shows a switch (32) situated at the outside of the lower housing, which switch serves to trigger or to separate any electrically controlled means of the puppet toy from a battery which is arranged within the lower housing (2).

Further the lower housing (2) comprises on its outer wall portion an acoustic trigger (31) such as typically used in key-finders which respond e.g. to a whistling sound, which trigger may be provided in order to put anyone of the electrical functions described hereinabove into operation in response to an acoustical signal.

Figures 12 and 13 show particular shapes for the lower housing such as a flower in figure 12 and a heart in figure 13.

These shapes of the housing have the particularity that they are not symmetric in the sense of rotation around the operating bar of the puppet toy and they are characterized in that the lower and upper openings are provided in wall portions which correspond to the surface created by the generatrix following the shape of a heart or of a flower, such as indicated in detail in figure 14. Figure 13 illustrates further an operating bar which comprises two upper ends, whereof each supports separate puppet (35) and (35').

Figure 14 shows in more detail a housing (34) in the shape of a heart such as in figure 13. The housing in form of a heart (34) comprises two wall portions which are more or less flat and which have the shape of a heart and a wall portion (36) which corresponds to the progression of the generatrix following the curve of the heart, which surface connects the edges of the two superposed hearts.

At the lower portion of the heart one can distinguish the upper opening (37) which has a dimension sufficiently large to permit a pivoting movement of the bar (5) which enters into the housing

(34) by the lower opening (6). Bar (5) such as mentioned under figure 13 comprises two upper ends (5a and 5b), each capable of carrying one puppet, the heads of which and the upper portions of their dresses being separated, whereas their lower portions and in particular the lower edge of the dresses are combined to one single lower edge which is squeezed between ring (3') and the periphery of the upper opening (37) such as to permit to attach the dresses of the two puppets within one single opening.

The present invention has been described by way of examples with reference to the drawings, however it is not limited to the illustrated embodiments and extends in particular to any combination of the illustrated characteristics.

Claims

1. Puppet toy of the type comprising a puppet (1) attached to the upper end of an operating bar (5) and comprising a lower housing (2) having an upper opening which is closed by a lower edge of the dress (4) of the puppet (1) and across which extends said operating bar (5), and a lower opening (6) which receives said operating bar (5), characterized in that the lower opening (6) is arranged such as to permit a pivoting movement of said bar (5) around a point which is situated at the lower opening.
2. The puppet toy of claim 1, characterized in that the operating bar (5) extends across the lower housing (2) whereby it traverses the lower and upper openings, the upper opening being larger than the lower opening.
3. The puppet toy according to claim 1, characterized in that said bar (5) comprises a rocking portion (7).
4. The puppet toy according to claim 3, characterized in that said rocking portion (7) is arranged on the bar (5) at a point which is situated within the puppet (1) and above the upper opening of the conical lower housing (2).
5. The puppet toy of claim 1, characterized in that it comprises a sound means (9).
6. The puppet toy of claim 5, characterized in that the sound means (9) is a sound mechanism.
7. The puppet toy of claim 1, characterized in that the sound means (9) is an electrical device.

8. The puppet toy of claim 5, characterized in that it is located within the lower housing (2).
9. The puppet toy of claim 8, characterized in that the sound means (9) is attached to the inner surface of the lower housing (2).
10. The puppet toy of claim 9, characterized in that the lower housing (2) comprises an opening in the proximity of the fixation of the sound means on the lower housing, in order to facilitate dissipation of the sound towards the exterior of the housing.
11. The puppet toy according to claim 1, characterized in that it comprises a light means (11).
12. The puppet toy according to claim 11, characterized in that the light means (11) comprises luminescent diodes.
13. The puppet toy according to claim 12, characterized in that the diodes (11) are arranged at the eyes of the puppet (1) and/or at any other desired location of the puppet.
14. The puppet toy according to claim 13, characterized in that the diodes (11) have selected colours.
15. The puppet toy according to claim 1, characterized in that it comprises stickers (12) which are attached to the lower housing (2) at any desired location.
16. The puppet toy according to claim 1, characterized in that it comprises a drive mechanism (13, 14) in order to drive the operating bar (5) into an axial reciprocating movement.
17. The puppet toy according to claim 16, characterized in that the driving mechanism comprises a pinion (13) which is driven into rotation and which comprises teeth (16) disposed on a portion of the periphery of said pinion (13) only, the operating bar (5) comprising a section having circumferential grooves (14) such as to permit the teeth (16) of the pinion (13) to engage within said grooves (14) and to provoke thus axial displacement of the bar (5) in response to rotation of the pinion (13).
18. The puppet toy according to claim 17, characterized in that said bar (5) is slightly solicited towards the opposite direction of the displacement imposed by the pinion (13), and it returns into its initial position when the portion of the pinion which does not comprise any teeth is opposing the grooves (14) of the bar (5).
19. The puppet toy of claim 1, characterized in that the operating bar (5) comprises at its upper end a portion (24) which is slightly enlarged such as to permit an elastic snap-in action of the bar into the interior of the head of the puppet (1) which comprises a corresponding recess (20), the entry (22) of which is slightly smaller than the enlarged portion (24) of the bar (5).
20. The puppet toy according to claim 19, characterized in that the head of the puppet (1) comprises a lower cylindrical collar (21) which surrounds the operating bar (5) and which carries an external circumferential groove (25) which serves for the attachment of the collar of the dress (4) of the puppet (1) by means of an elastical or non-elastical string.
21. The puppet toy according to claim 5, characterized in that it comprises a trigger button (10) for the electrical current which is provided by a battery which is situated at the interior of the lower housing, by which trigger button the sound mechanism (9), the light means (11) and/or the driving mechanism (13) for the operating bar (5) may be put into or out of action.
22. The puppet toy according to claim 1, characterized in that the lower housing (2) comprises the shape of a straight cone.
23. The puppet toy according to claim 1, characterized in that the lower housing (2) comprises the shape of a cylinder or a barrel.
24. The puppet toy according to claim 1, characterized in that the lower housing (2) comprises the shape of a heart.
25. The puppet toy according to claim 1, characterized in that the lower housing (2) comprises the shape of a flower.
26. The puppet toy according to claims 24 or 25, characterized in that the upper opening and the lower opening are arranged in a wall portion (36) which corresponds to the surface created by the generatrix following the curve of a heart or of a flower.
27. The puppet toy of claim 26, characterized in that the lower edge of the dress (4) is fixed within the upper opening (37) of the housing in

the shape of a heart (34) or of a flower (33) by means of a ring (3') which engages within said opening.

28. The puppet toy according to claim 1, characterized in that the lower housing (2) comprises a hollow projection (29'), a hollow portion of which communicates with a lateral opening (29), which hollow portion houses a whistle means, the hollow projection also serving for the attachment of a flexible tube (27), the free end of which carries a mouth piece (30) permitting to actuate the whistle means by blowing into the mouth piece (30).
29. The puppet toy according to claim 7, characterized in that the lower housing (2) comprises a switch (32) by which any electrically driven means of the puppet toy may be separated from or connected to a battery which is located within the lower housing.
30. The puppet toy according to claim 7, characterized in that it comprises an acoustical trigger (31) which is provided to trigger any electrical function of the puppet toy such as the sound means (9), the light means (11) and/or the driving mechanism (13, 14).

5

10

15

20

25

30

35

40

45

50

55

7

PRIOR ART

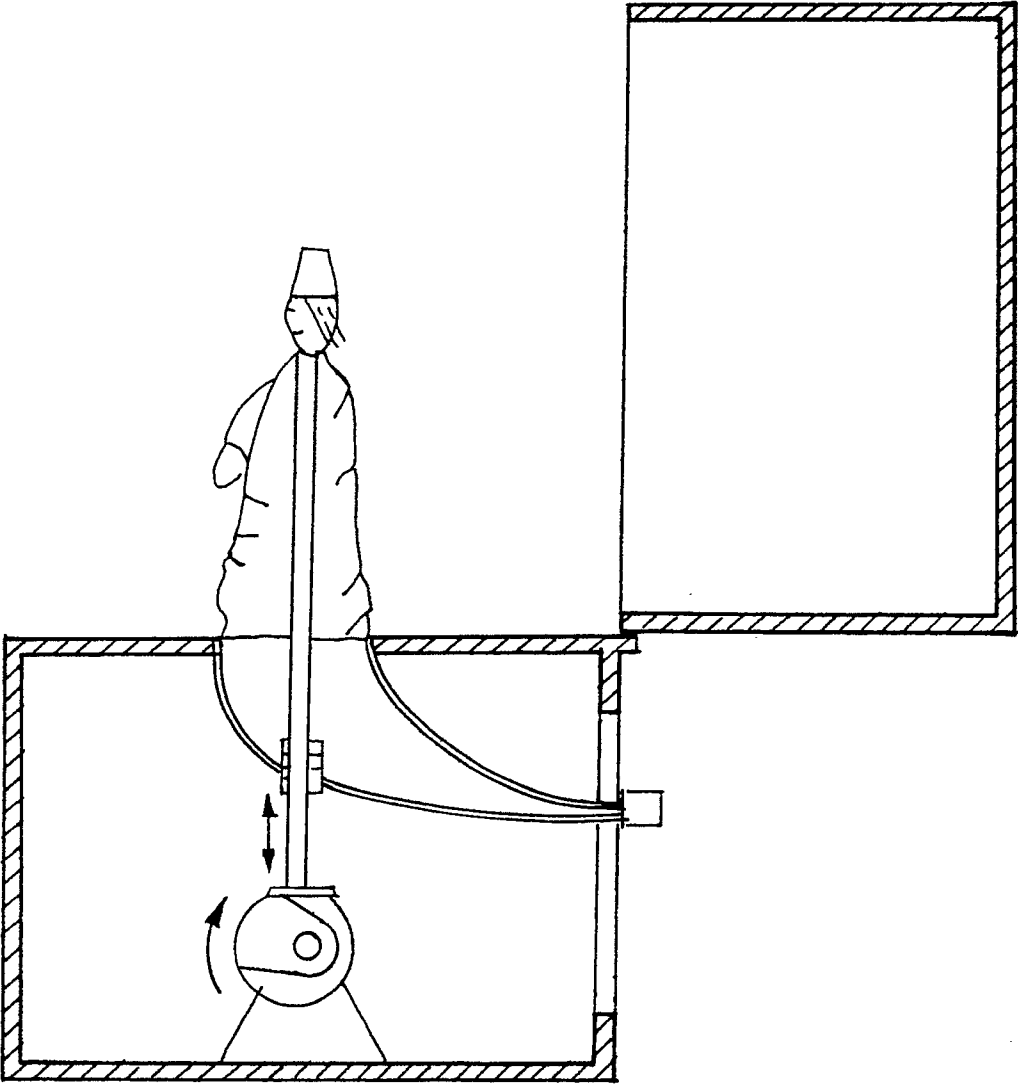

Fig. 1

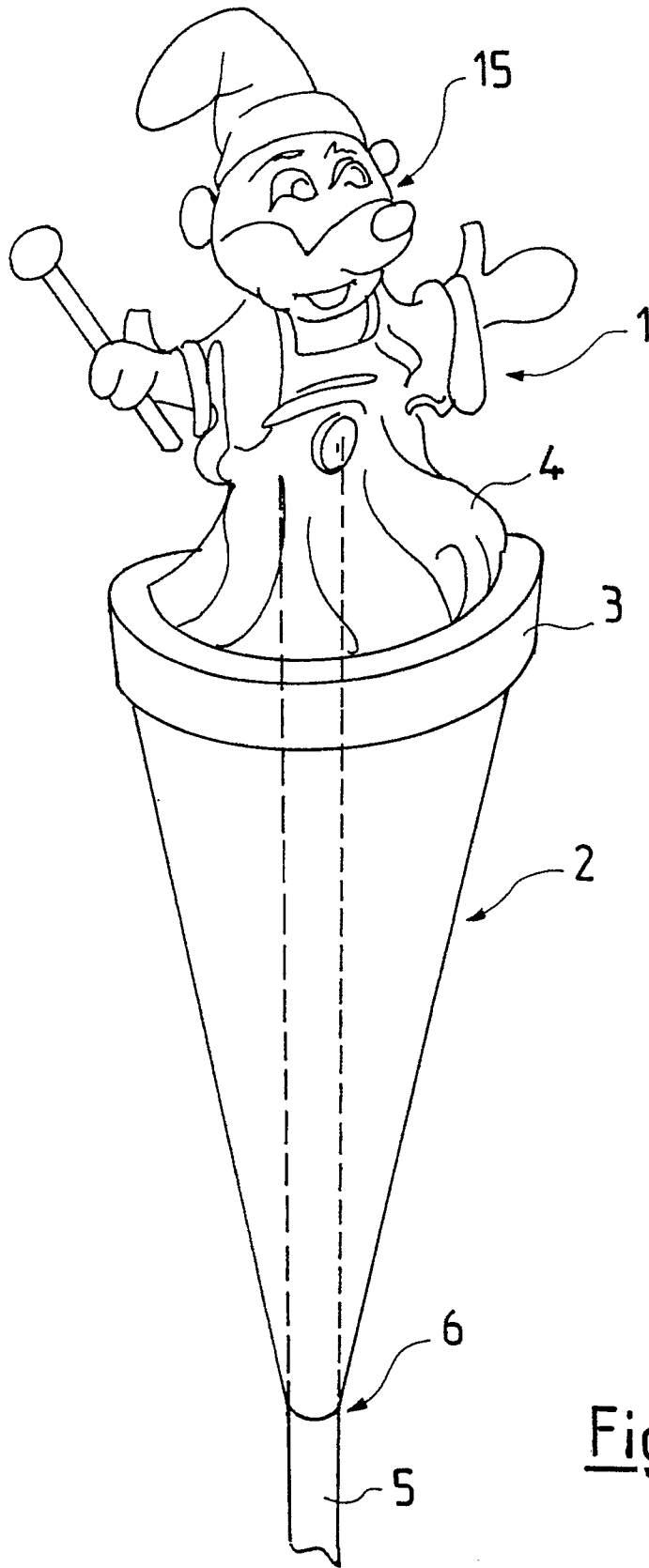

Fig. 2

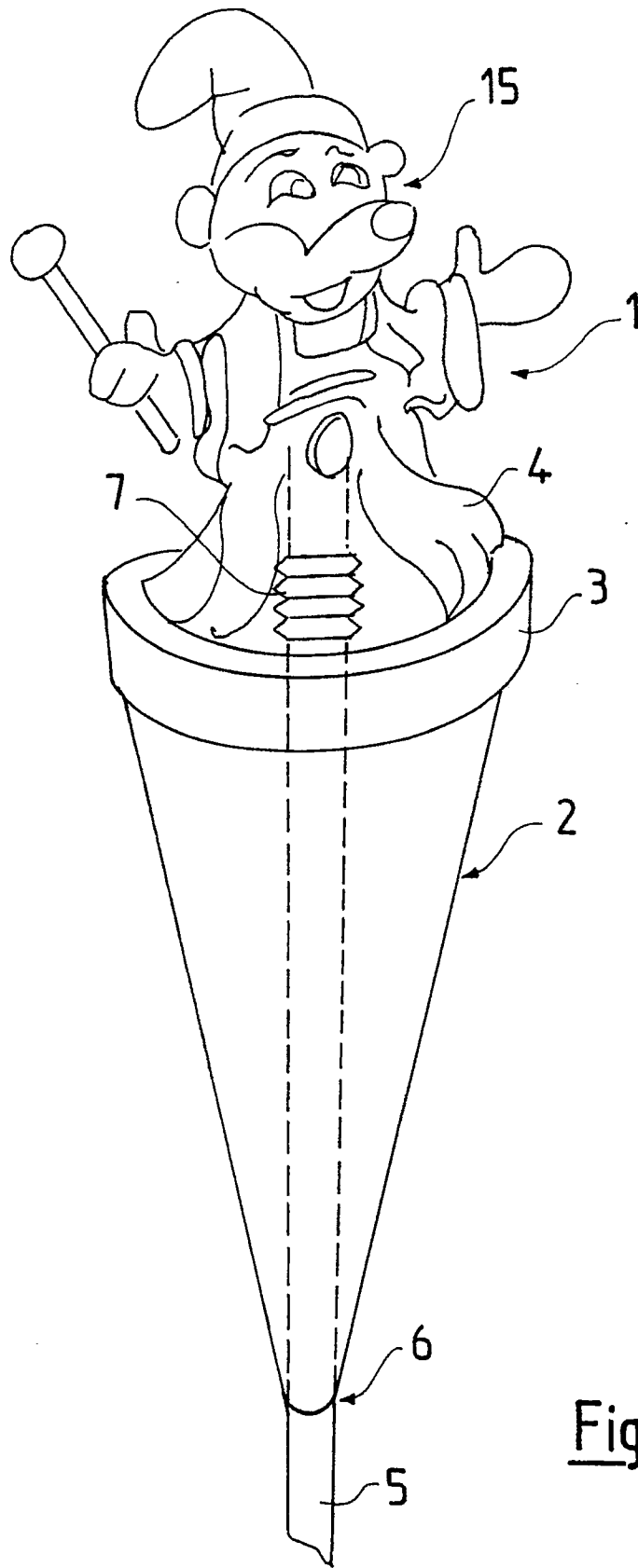

Fig. 3a

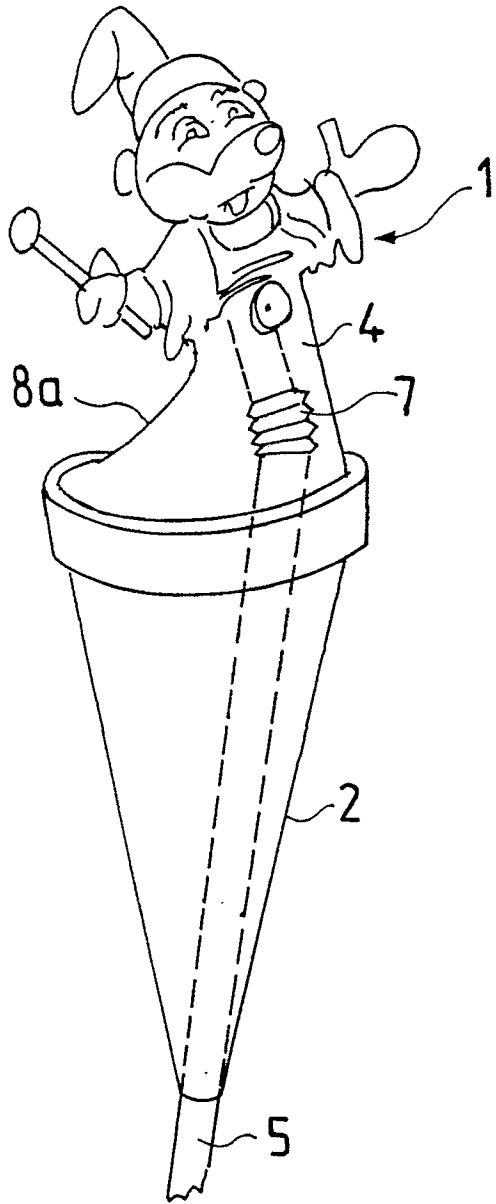

Fig. 3b

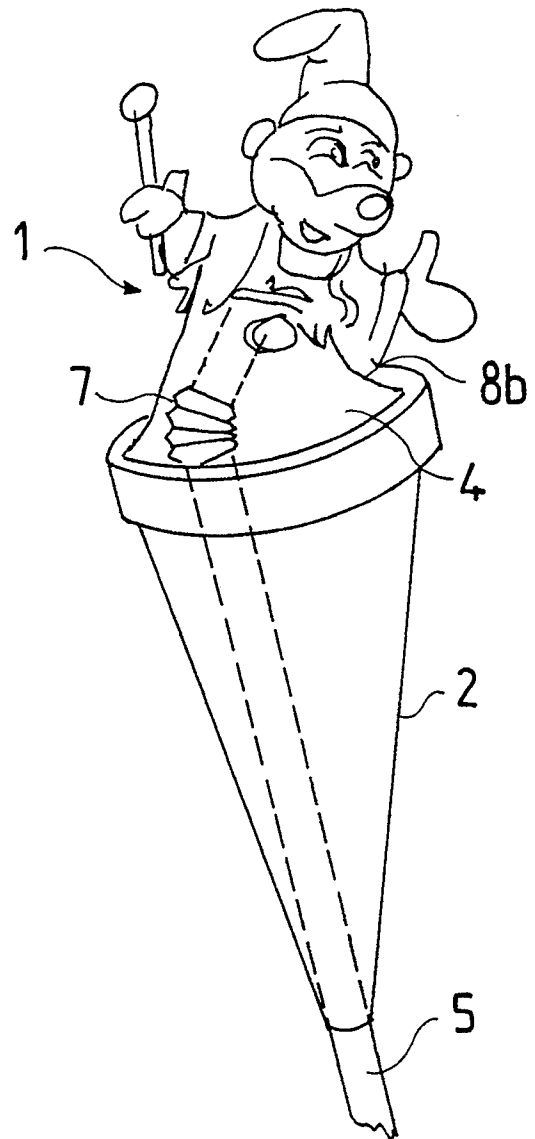

Fig. 3c

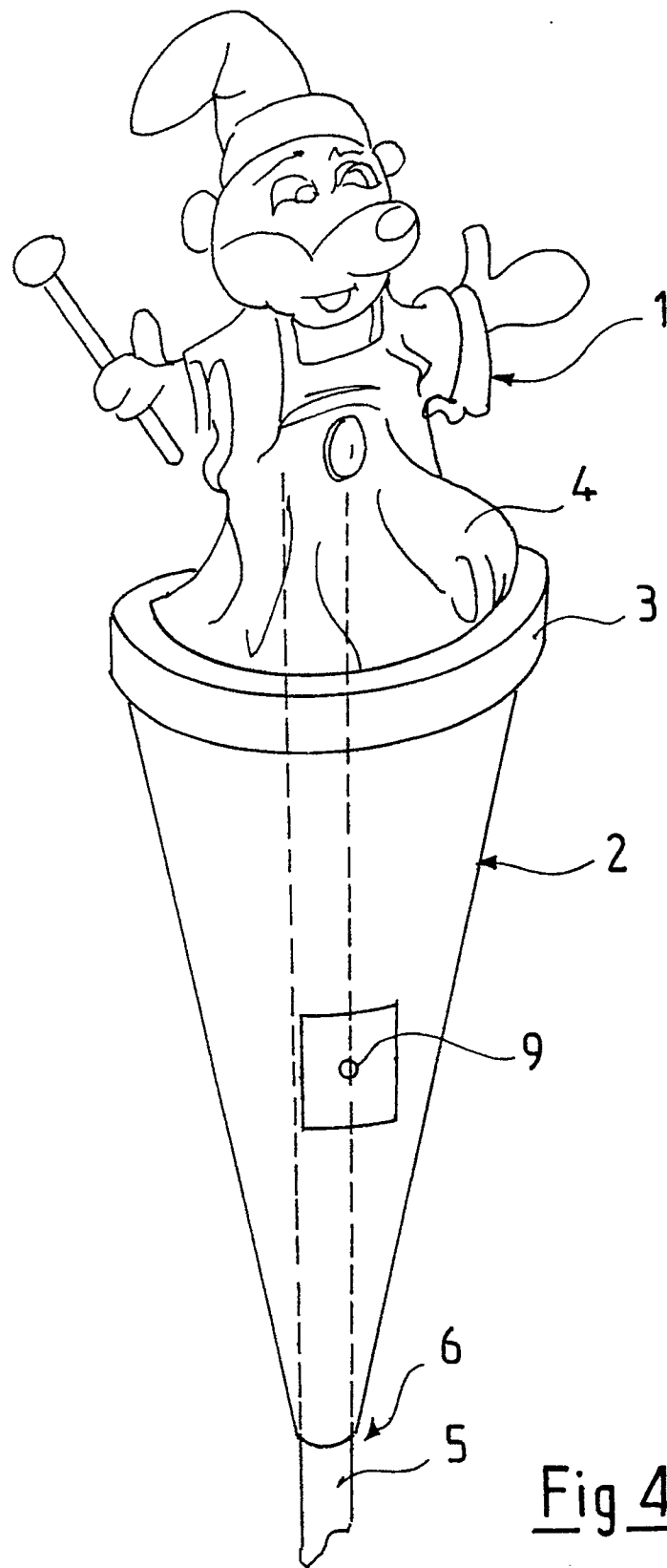

Fig 4

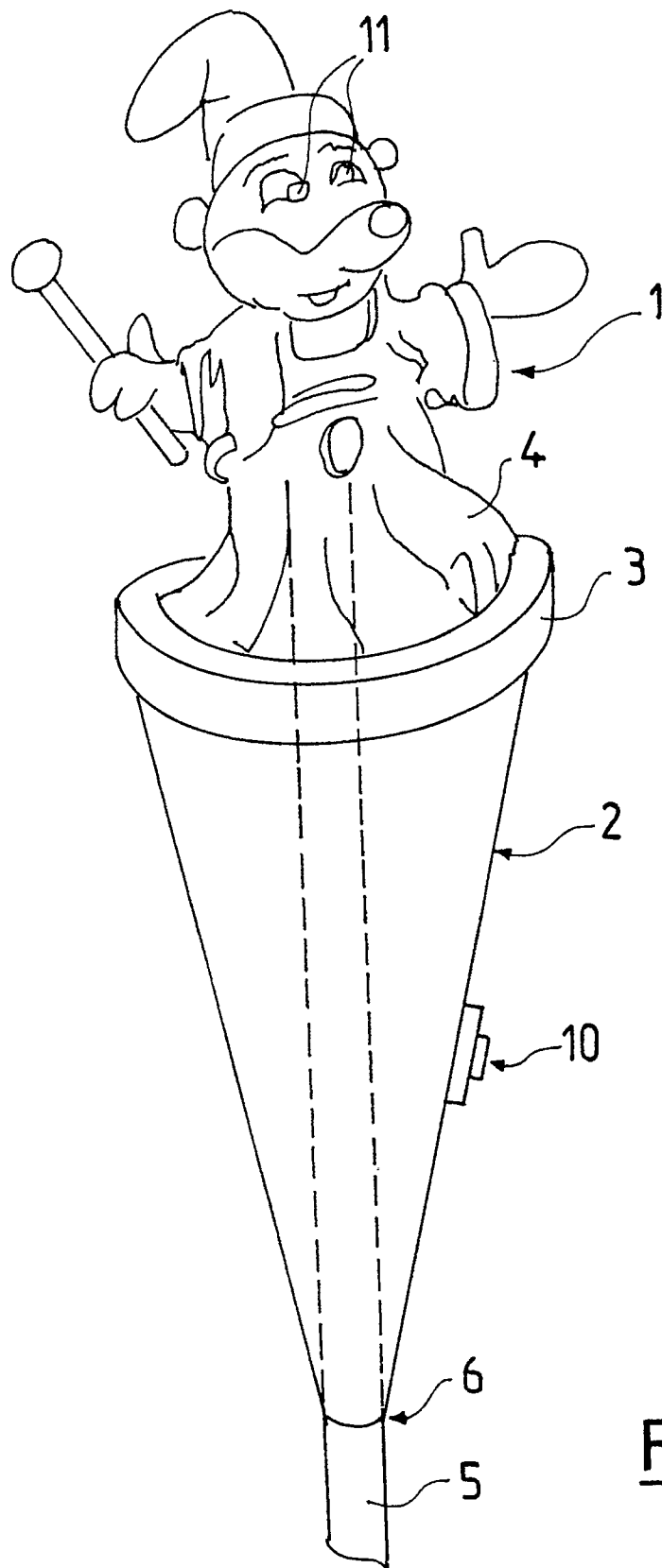

Fig 5

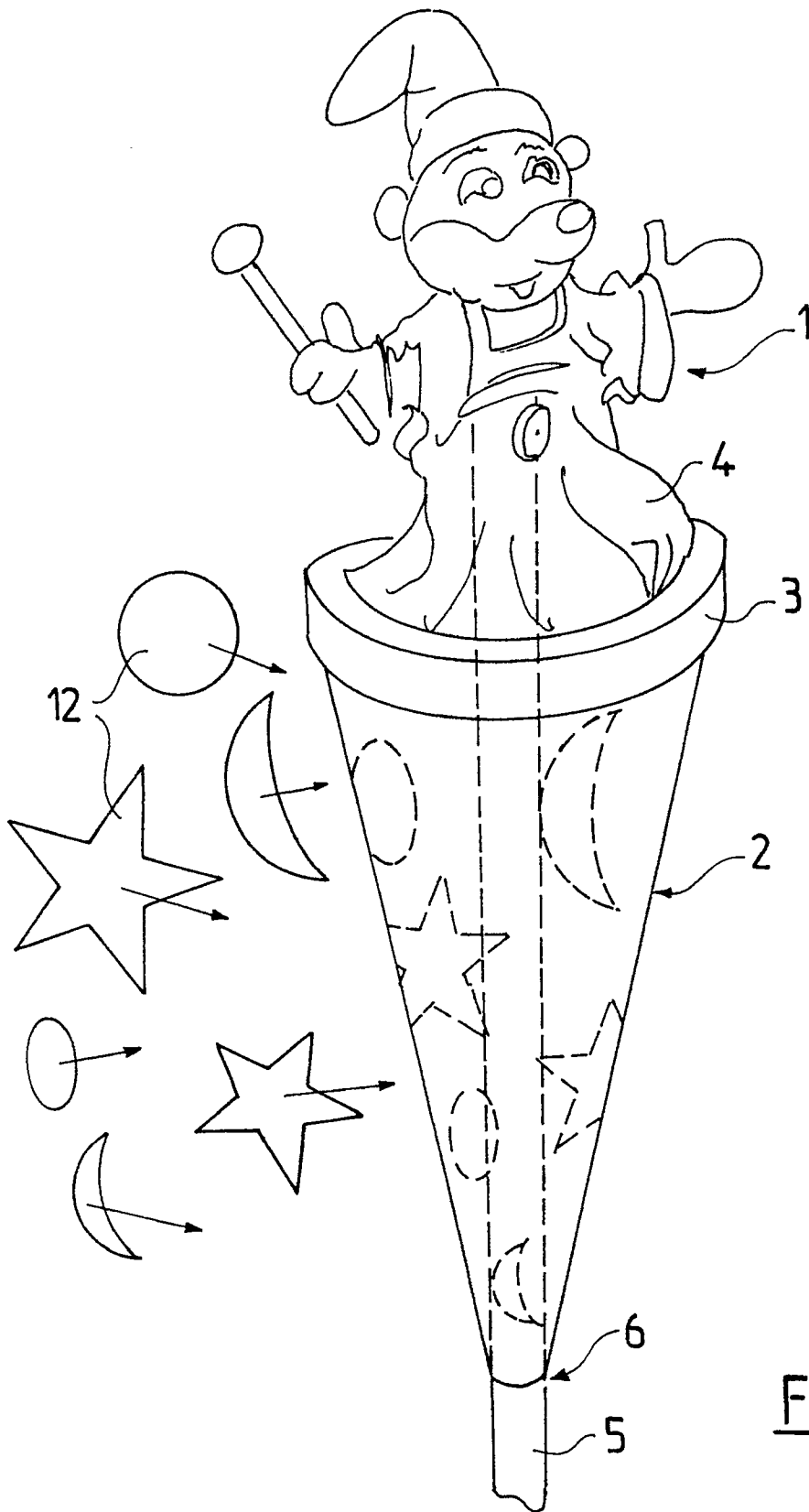

Fig 6

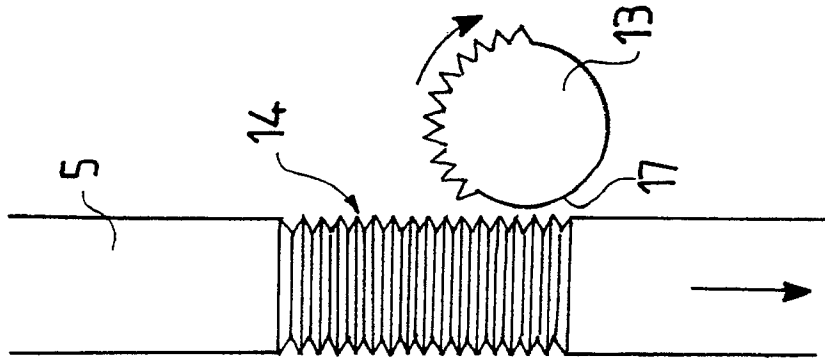

Fig. 7c

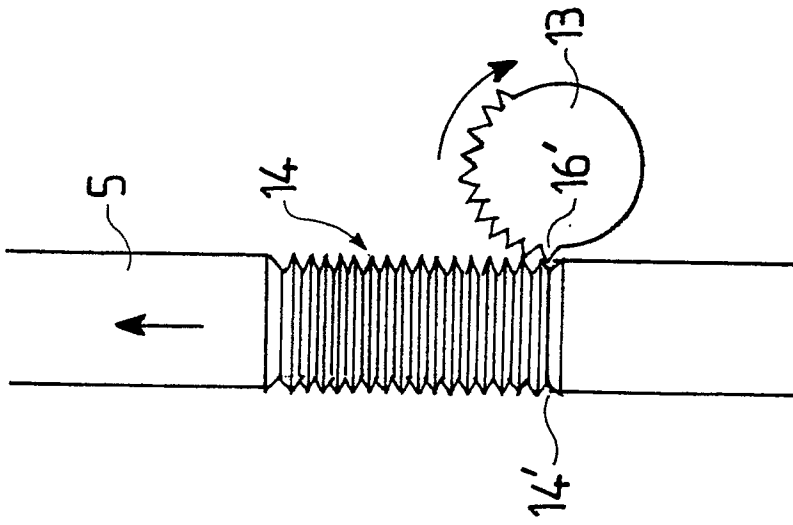

Fig. 7b

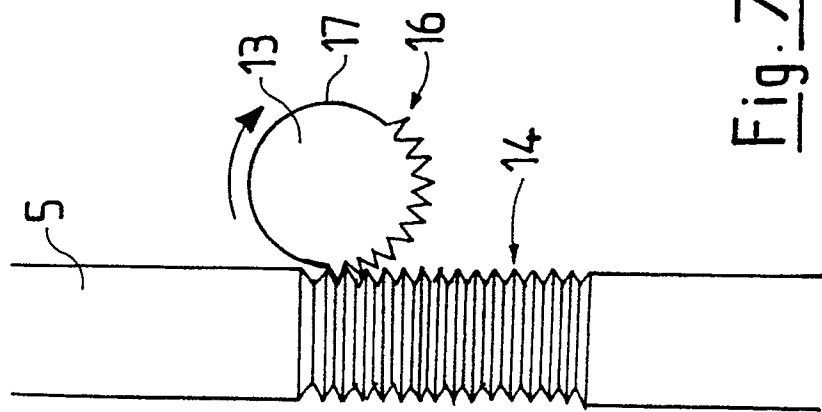

Fig. 7a

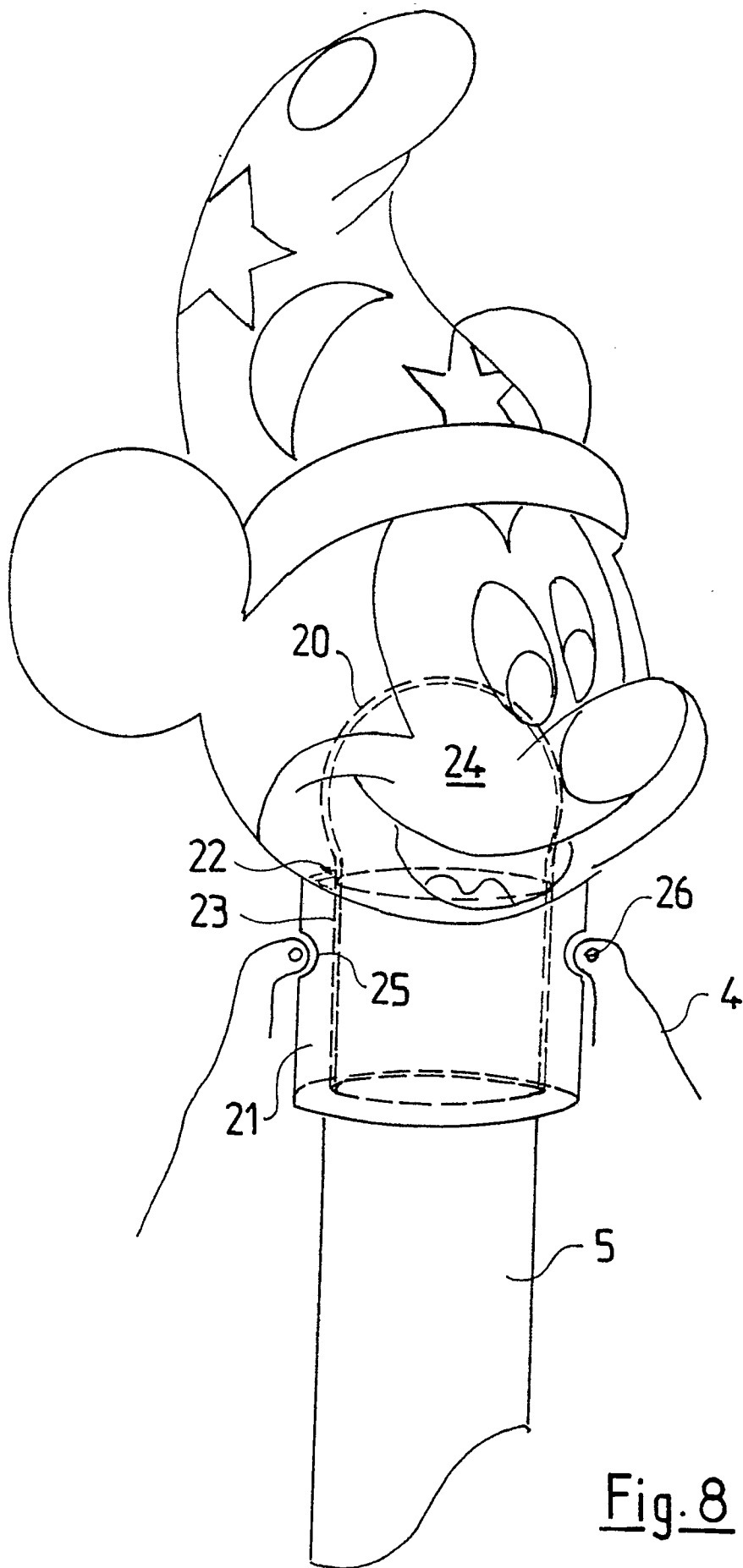

Fig. 8

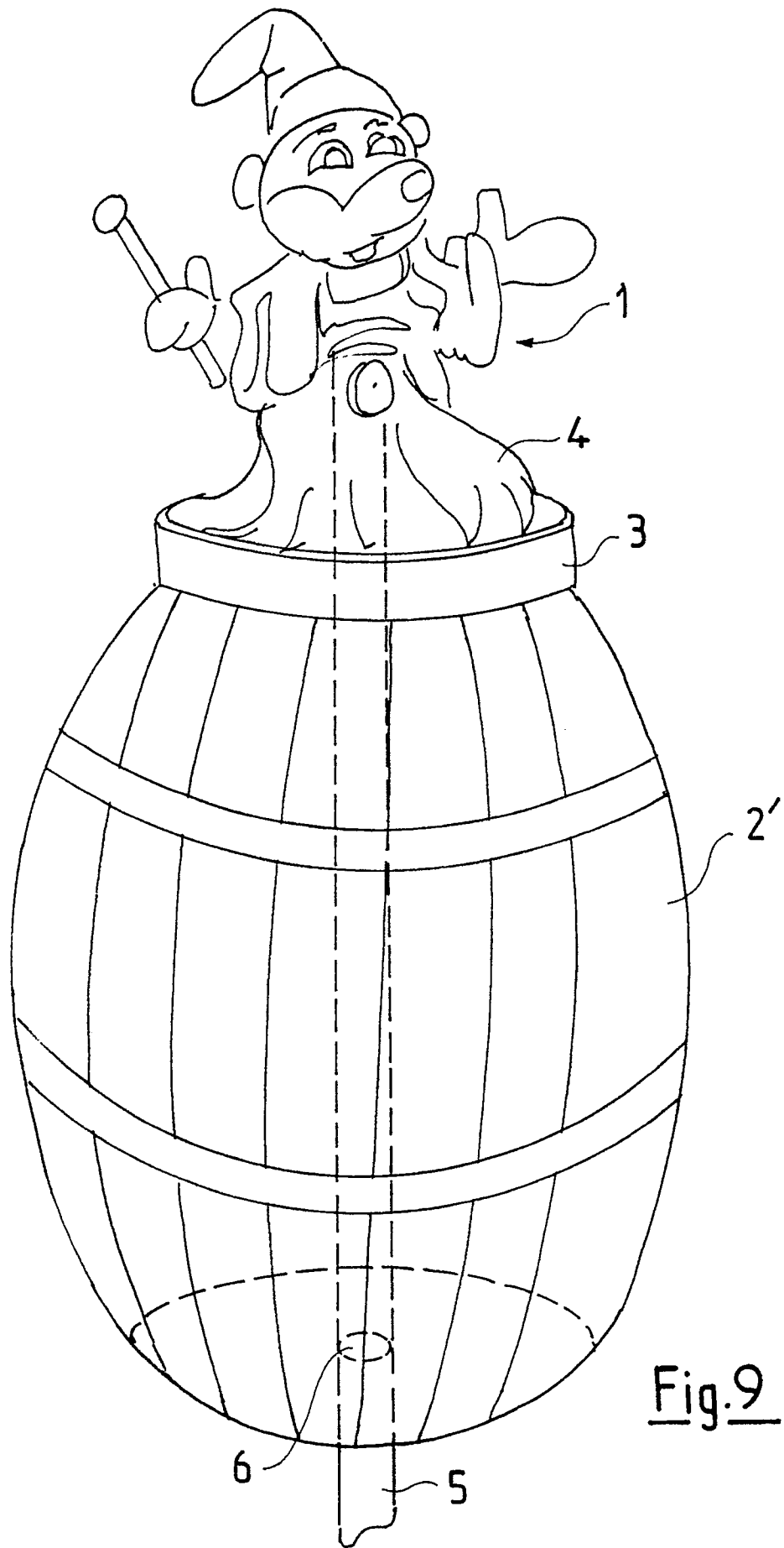

Fig.9

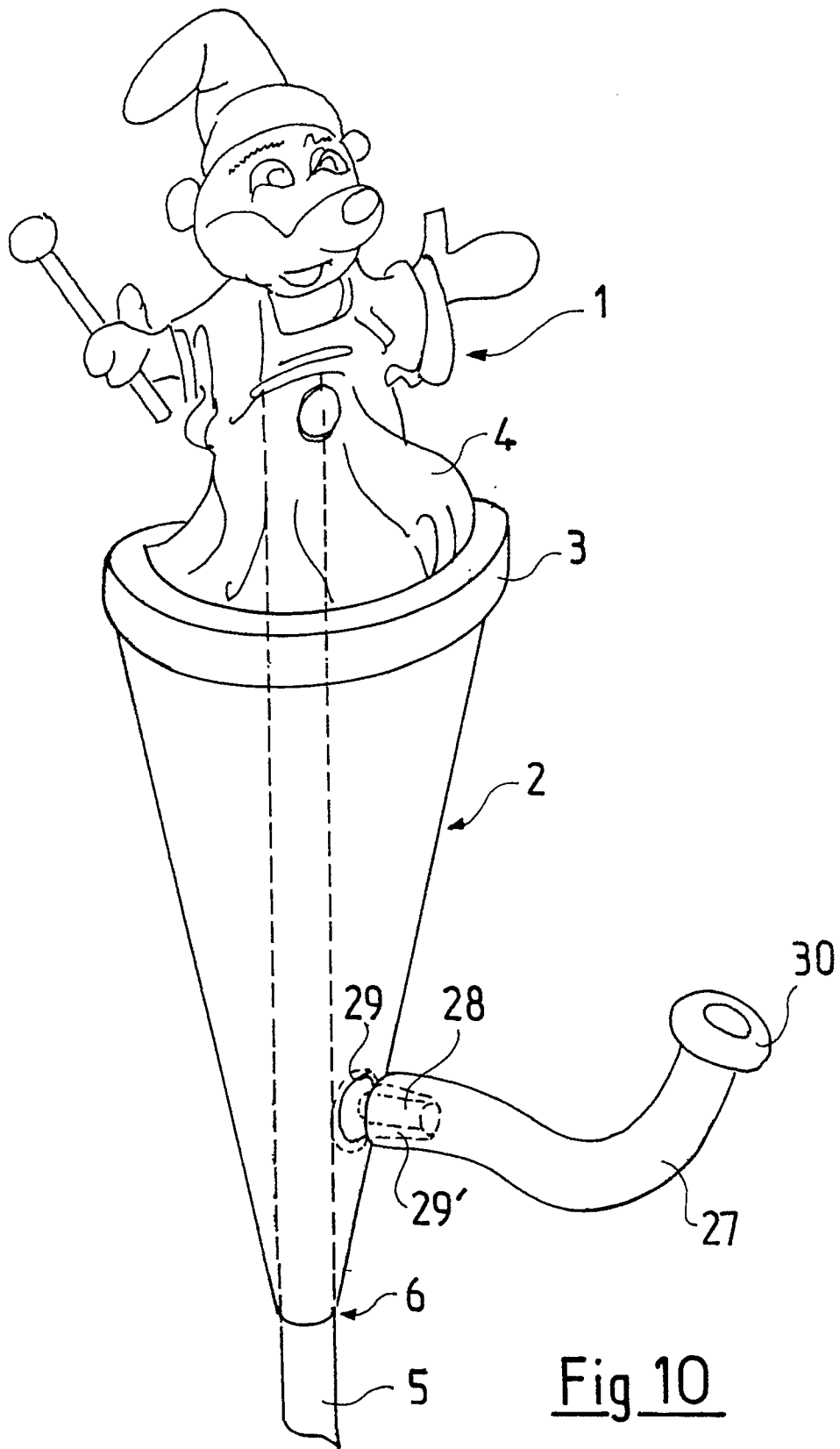

Fig 10

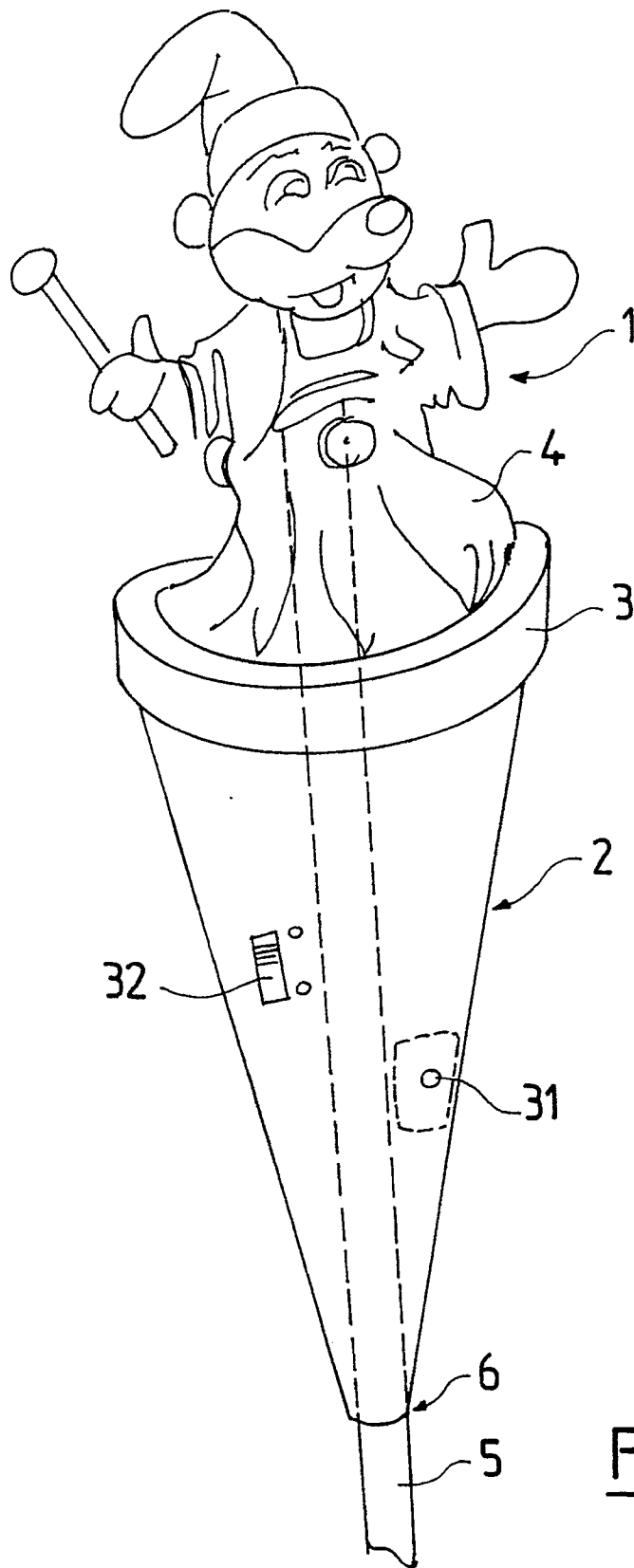

Fig 11

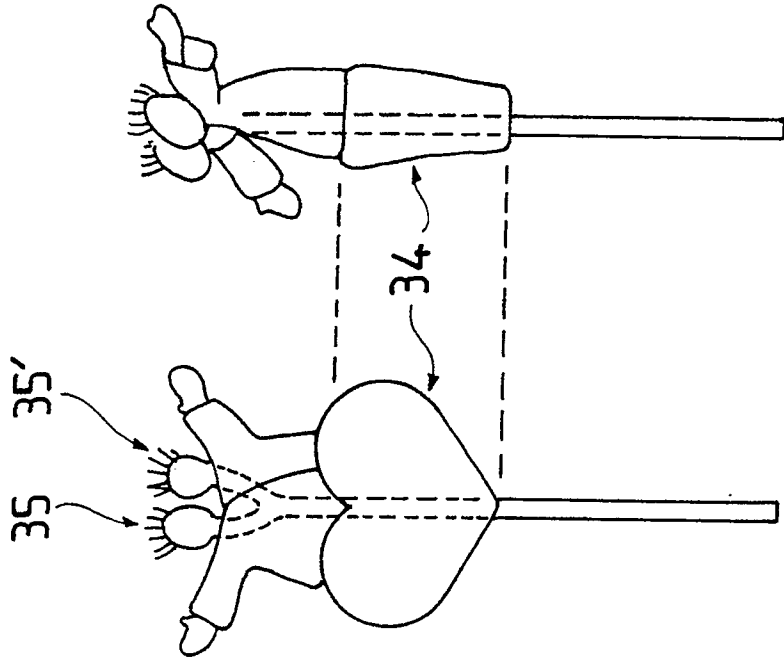

Fig 12

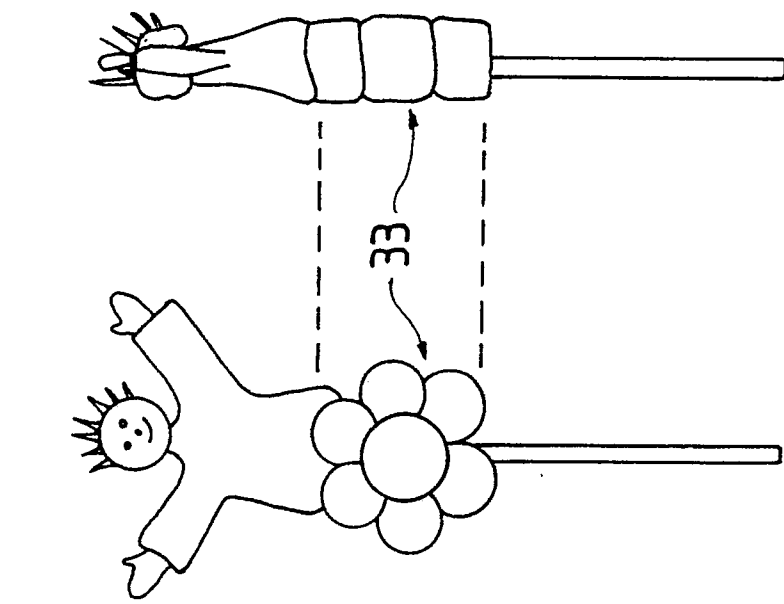

Fig 13

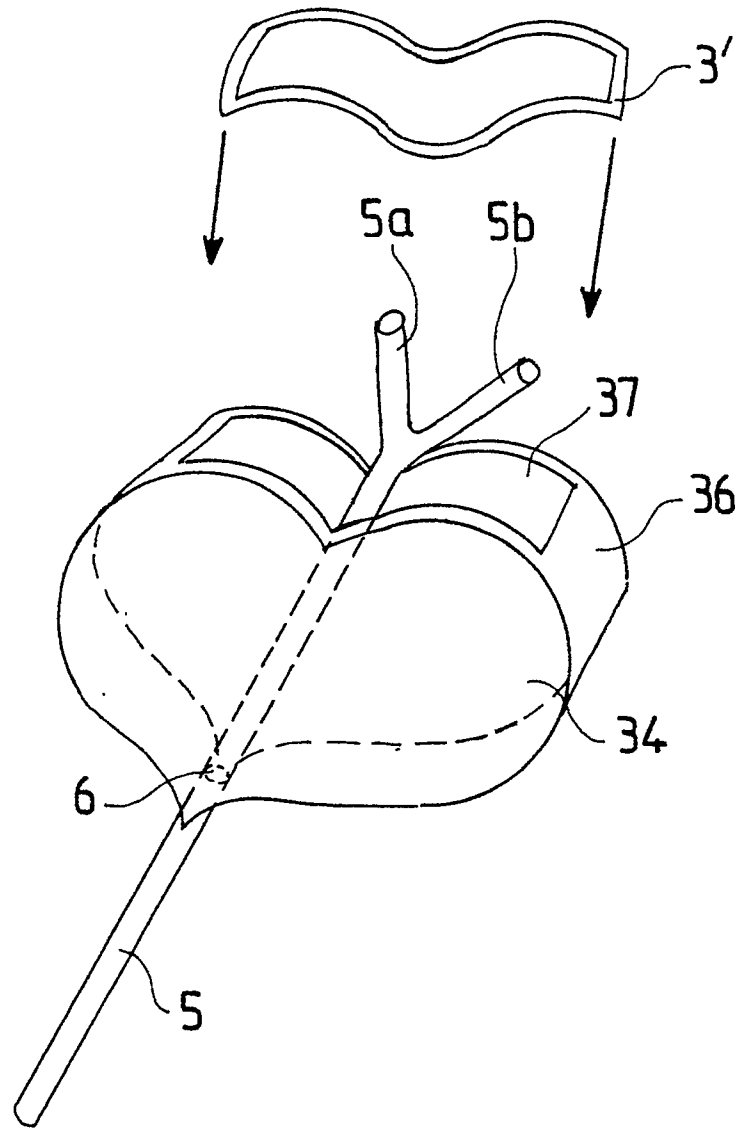

Fig 14



**EUROPEAN SEARCH
REPORT**

DOCUMENTS CONSIDERED TO BE RELEVANT			
Category	Citation of document with indication, where appropriate, of relevant passages	Relevant to claim	CLASSIFICATION OF THE APPLICATION (Int. Cl.5)
X	US-A-3 471 966 (KRATZER) * Whole document *	1,2	A 63 H 7/00 A 63 H 3/20 A 63 J 19/00
Y	-----	5-14,16, 22,23,28	
X	US-A-4 245 428 (BOWEN) * Abstract; column 4, lines 21-24; figures 1,3,4 *	1,2	
A	-----	15	
Y	US-A-4 237 647 (SHAW) * Column 2, lines 40-49; claims *	5-11	
Y	GB-A-2 057 277 (SHIN GONG CO., LTD) * Claims 1-4 *	12-14	
D,Y	US-A-4 804 348 (BONDI') * Abstract *	16	
Y	US-A-3 763 591 (FONTANA) * Abstract; figures 1,3,7 *	22,23,28	

			TECHNICAL FIELDS SEARCHED (Int. Cl.5)
			A 63 H A 63 J
The present search report has been drawn up for all claims			
Place of search		Date of completion of search	Examiner
The Hague		10 May 91	SANCHEZ Y SANCHEZ J.
<p>CATEGORY OF CITED DOCUMENTS</p> <p>X: particularly relevant if taken alone Y: particularly relevant if combined with another document of the same category A: technological background O: non-written disclosure P: intermediate document T: theory or principle underlying the invention</p> <p>E: earlier patent document, but published on, or after the filing date D: document cited in the application L: document cited for other reasons</p> <p>..... &: member of the same patent family, corresponding document</p>			